



WORKS FOR NATURE.

WORKS FOR YOU.



**ECO-FRIENDLY GREEN PANELS WITH  
CYCLOPENTANE PUF INSULATION**

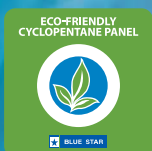

Blue Star is India's leading airconditioning and refrigeration company with over 7 decades of experience in providing commercial refrigeration solutions of every kind. With products designed, developed and manufactured at five state-of-the-art plants across India, and supported in every corner of the country through 23 offices and over 500 dealerships.

The company is known for its innovation and technological leadership and has introduced many cutting-edge products and solutions into the Indian marketplace which offer higher efficiency, better performance and more reliability—factors that matter most to the customer.

Blue Star also ensures that every new solution it brings to the marketplace is eco-friendly and green, and contributes to a sustainable future of reduced global warming and zero ozone depletion. The introduction of the eco-friendly R410a refrigerant in most of its airconditioning solutions, for example, goes a long way in helping the country meet its obligations to reduce the use of HFCs under the Montreal Protocol.

The company now introduces eco-friendly pre-fabricated insulation panel systems in a range of profiles, thicknesses, and finishes. The speciality of these panels is that, they are perfect for the speedy creation of cold stores of any size at the site due to their precise interlocking design and great insulation properties, and are also eco-friendly both in their material and in their manufacturing process itself.

These new eco-friendly panel solutions from Blue Star can be used to create cold storages of any size, from small walk-ins to very large cold rooms.





## The Perfect Cold Room

A cold storage is a critical piece of infrastructure for any industry. The quality of stored produce and raw material depend upon the reliable and precise functioning of the cold storage.

Blue Star's experience in creating cold storages that offer different storage conditions in terms of temperature, humidity, fresh air, air flow, etc., to suit different industry requirements has made them the leaders in this domain too.

The company's engineers plan and design cold rooms based on advanced heat load calculations using internationally acclaimed softwares thus building your desired cold room with precision.

**Blue Star's Cold Storage Division's domain expertise extends across a wide spectrum of industries that includes:**

**FMCG**

**Floriculture**

**Horticulture**

**Agro Industry**

**Hotels & Restaurants**

**Food Processing**

**Meat Processing**

**Fisheries**

**Pharmaceuticals**

**Ripening Chambers**

**Research & Development Labs**

**Healthcare**

**Mortuaries**

**Cold Chains**

**Auto Industry**

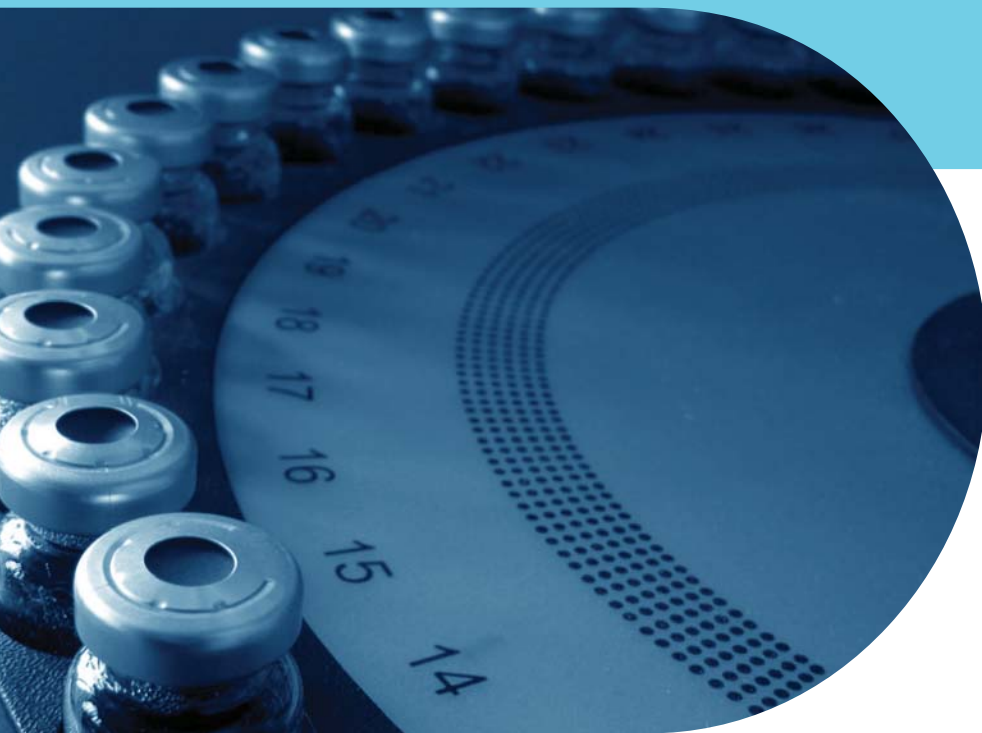

## Pre-fabricated from Blue Star

### **Panels**

Blue Star's new range of pre-fabricated insulation panel systems are easy-to-use interlocking panels that can be used to create cold rooms of any size at the site.

Since the insulation material in these panels is foamed between two metal skins, they offer highly effective insulation for cold rooms.

What's more, these panels are designed to ensure precision interlocking and hence they form leak-free walls ideal for cold rooms.

Manufactured in a wide range of profiles, thicknesses and finishes, these systems can be used to create cold stores at the site and of any size – from small walk-ins to very large cold rooms.

### **Doors**

Blue Star offers a complete range of insulated doors to complement its world-class environment-friendly PUF panels.

The polyurethane foam insulation sandwiched between GI sheets makes the doors perfect for high-performance cold rooms.

- Self-closing: Ensures that the door remains closed without any human interaction
- Safety release: Doors can be opened from inside
- View port: Helps view products stored inside without opening the door, which is not just for convenience but for power saving too.

- Posi Seal: Provides perfect alignment of frames and ensures perfect closing movement
- Sweep gasket: Air-tight heavy-duty sealing gasket below the door remains flexible at any temperature
- Thermal break: Eliminates thermal conductivity which otherwise leads to condensation and ice formation

## An Eco-friendly DNA

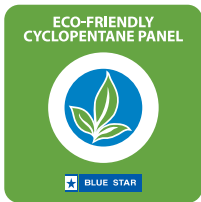

### Panel Systems

Blue Star's new range of pre-fabricated insulation panels are eco-friendly from the ground-up since even the manufacturing process is green.

#### **Cyclopentane: The eco-friendly blowing agent**

Cyclopentane is increasingly becoming an industry standard the world over as an eco-friendly blowing agent. Blue Star has also invested in using cyclopentane as the blowing agent in the manufacture of its new series of insulation panels. This makes the panels 'green' even in their manufacturing process, and further underlines Blue Star's commitment to a greener tomorrow.

This ensures zero Ozone Depleting Potential (ODP) and reduces Global Warming Potential (GWP) as compared to the more generally used HCFC-141b which is not environment friendly.



### Why cyclopentane

- ODP (Ozone depletion potential): 0
- GWP (Global Warming Potential): Negligible (11)
- Complies with TUV standards, CCOE (India) certification

Blue Star's commitment to a healthy environment is thus further reinforced by this investment in a cyclopentane process, which not only ensures superior yet environmentally friendly products, but also supports India's obligations under the Montreal Protocol on 'Substances that Deplete the Ozone Layer'.

### Cyclopentane vs Conventional HCFC-141b :

S.N	Particulars	HCFC 141b	Cyclopentane
1	Density (Kg/m <sup>3</sup> )	35-37	37-40
2	Compressive Strength (Kg/cm <sup>2</sup> )	1.5-1.8	1.6-1.9
3	Closed Cell Content (%)	> 90	> 90
4	K- value (w/m °K)	0.0195	0.022
5	GWP (Global-warming potential)	630	11
6	ODP (Ozone-Depletion Potential)	0.1	0
7	Fire retardant property	Self-extinguishing	Self-extinguishing

### CFC and HCFC-free polyurethane

The insulation material used within Blue Star's new range of pre-fab panel systems is also eco-friendly, being made of CFC/HCFC-free polyurethane.

This is in accordance with India's obligations under the Montreal Protocol on 'Substances that Deplete the Ozone Layer', which the 'Ozone Cell' (specially created within the Ministry of Environment, Govt of India) is driving under the 'HCFC Phase Out Management Plan (HPMP) Stage 1B'.

Facilities aiming to become green buildings will find these panels ideal for their LEED certification process.

## Precision Locking Mechanism

Each Blue Star pre-fab insulation panel has cam-action locking devices precisely positioned and firmly anchored within it. All cam-locks have integral rear flanges to permanently anchor their position during the manufacture of the PUF panels. Cam-locks are also placed at exact matching locations on the tongue and groove side to ensure perfect locking.

All cam-locks are accessible from the inside by means of a hex wrench furnished with the panels. Access ports for cam-locks are covered with snap-in cap plugs that must be snapped out before accessing the cam-locks thus making them tamper-proof.

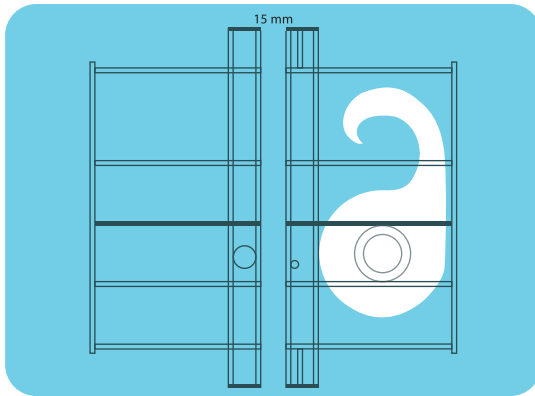

BEFORE LOCKING THE PANELS

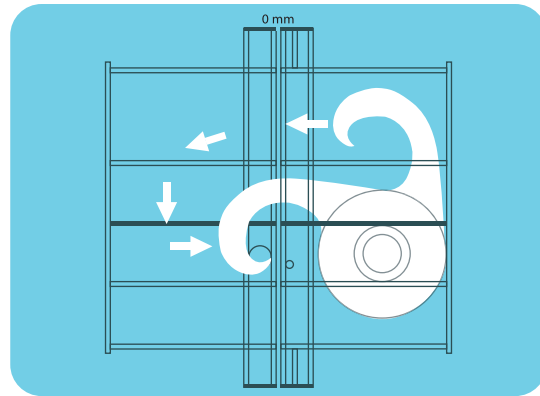

AFTER LOCKING THE PANELS

## Technical Specification

SI.No	Description	General Specifications
1	PUF Panel Thickness	40/60/80/100/127mm
2	PUF Panel Cover	PP or SS
3	Sheet Metal Thickness	0.4/0.5mm
4	Temperature Range	-30°C to 80°C
5	PUF Blowing Agent	Cyclopentane (C5) - (CFC & HCFC free)
6	Lock Arrangement	Cam-Lock with metal plunger
7	PUF Density	40Kg/m <sup>3</sup>
8	Panel Length	Any lengths upto 14m on request
9	Panel Width	11.5/ 23/ 34.5 / 46 inches
10	Panel Joint	Tongue & Groove joint
11	Panel to Panel Fitment	The gap between two fitted panels < 3 mm

## Features & Benefits



PUF insulation core ensures excellent K factor



High density polyurethane offers better strength



Perfect joints eliminate air leakages



Effective thermal insulation results in negligible thermal conductivity



Suitable for a wide temperature range of -30°C to +80°C



In case of fire, stops burning when source of fire is removed



Occupies less space due to efficient insulation



Eco-friendly blowing agent cyclopentane used



Modular construction resulting in faster installation

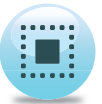

Easily expandable to larger sizes



Available in stainless steel and pre-painted GI



Thickness range from 40mm to 127mm



90° corner panels to ensure stability



## Wide Range of Refrigeration Units

Blue Star offers a wide range of both evaporating and condensing units. It includes both air-cooled and water-cooled condensers, with technology from the world leaders.

Depending on the application, different temperature zones need to be maintained:

Low (-23 °C to -5 °C), Medium (-5 °C to +2 °C), High (+2 °C to +15 °C)

### Evaporating units

Blue Star's evaporating units are compact, slim and sleek, so they occupy minimum space ensuring maximum storage space. Other features include:



Stainless steel body and excellent corrosion resistance



Inner grooved copper tubes for superior heat transfer



In-built defrost heaters for low-temperature units



External rotor driven fans with low noise levels



Removable side panels for easy service



Drain on same side of refrigeration to avoid making multiple openings in the PUF panels



## Condensing Units

These units are characterised by high-efficiency heat transfer and low power consumption. Other features includes:



Energy-efficient scroll and reciprocating compressors



UV and corrosion resistance



Filter drier for moisture and dirt protection



Pre-charged unit with service valves



In-built safety and control devices



Weather-proof polyster powder coated canopy



## Microprocessor Controller and Power Panel

Blue Star's refrigeration units come with intelligent microprocessor-powered controllers which are BMS compatible and HACCP provisioned (available in select models).

Ready-to-use power panels which make electrical connections simple, safe, fast and long-lasting are available with every refrigeration unit. Other features of power panels are:

- Powder-coated weather proof housing
- Protection against common electrical failures
- Interlock of safety features

## Perfect Installations

Without carefully executed installations, the efficiency and reliability of a cold room can be compromised. Hence Blue Star's engineers are equipped with latest technology and knowledge thus carrying out precise installations. Example checks considered by them are:

- The location of the evaporator within the cold room for uniform cooling and air distribution
- Level Flooring (0-0 level) to avoid misalignment of walls
- Proper selection of copper parts and pipe sizes
- Minimising bends and unduly long runs

## After Sales Support

Blue Star is well known for its excellent service support in the entire industry. With a team of specially trained technicians placed at 17 destinations across India, you can expect absolutely smooth service support. Cold Room dealers based in different locations will help you with perfect installations and Blue Star will ensure after sales support and availability of genuine parts at all times to avoid down time of your project.





For more information, please contact **BLUE STAR LIMITED • Ahmedabad:** 301 & 302, (3rd Floor), Abhishree Avenue, (Near) Nehru Circle, SM Road, Ambawadi, Ahmedabad - 380 015. Tel: (079) 40224000 • **Bengaluru:** Anjuman KAY A R R Tower No - 28, Ward No 77, Mission Road, Bangalore - 560027. Tel: (080) 41854000 • **Bhubaneshwar:** 3A, Satya Nagar, 2nd Floor, Bhubaneshwar - 751 007. Tel: (0674) 2572403 / 2573670 • **Chandigarh:** Adarsh Mall, 4th Floor, Plot No. 50, Industrial & Business Park, Phase - II, Chandigarh - 160 002. Tel: (0172) 5024000 • **Chennai:** No.104, Old No. 46, 'Garuda buildings', Cathedral Road, Chennai - 600 086. Tel: (044) 42444000 • **Ghaziabad:** C 53A, Third Floor, Rajnagar District Center (RDC), Raj Nagar, Ghaziabad - 201001, Uttar Pradesh. Tel No: (0120) 2821400 • **Goa:** 210, 2nd Floor, Gera's Imperium I, Patto, Panjim, Goa - 403 001. Tel: (0832) 2438171/2437287 • **Gurgaon:** Block 2-A, DLF Corporate Park, DLF Qutab Enclave, Phase III, Mehrauli-Gurgaon Road, Gurgaon - 122 002. Tel: (0124) 4094100 • **Guwahati:** Oasis Plaza, Dr. B. Barooah Road, Ulubari, Kamrup, Guwahati - 781007. Tel: (0361) 2468496 • **Indore:** Shri Krishna Classic, First Floor, 139, Phadnis Colony, AB Road, Indore - 542 010. Tel: (0731) 4001211/4001311 • **Jaipur:** A-19, 1st Floor, Main Sahakar Path, Near Sahakar Bhavan, Jaipur - 302 001. Tel: (0141) 2744033-35 • **Kochi:** 2nd Floor, Millennium Plaza, MKK Nair Road, Alinchuvadu Junction, Kochi - 682 024. Tel: (0484) 4499000 • **Kolkata:** 7, Hare Street, Kolkata - 700 001. Tel: (033) 22134100 • **Ludhiana:** SCO 16-17, Feroze Gandhi Market, Fortune Chambers, 3rd Floor, Ludhiana - 141001 (Punjab), Tel: 0161 5001404 • **Lucknow:** 177/4, Faizabad Road, Lucknow - 226 007. Tel: (0522) 4034000 • **Mumbai:** Blue Star House, 9-A, Ghatkopar Link Road, Saki Naka, Mumbai - 400 072. Tel: (022) 66684100 • **Nagpur:** 219, Bajaj Nagar, 1st Floor, South Ambazari Road, Nagpur - 440 010. Tel: (0712) 2249000 / 6624000 • **Pune:** 201/A, Nityanand Complex, 1st Floor, 247/A, Bund Garden Road, Pune - 411 001. Tel: (020) 41044000 / 26169332 • **Raipur:** Alaska Corporates, 3rd Floor, Opp. VIP Road, Jivan Vihar Colony, G E Road, Raipur, Chhattisgarh - 492 006. Tel: (0771) 6544000 • **Secunderabad:** 207, Sikh Road, Bantia Estate, Secunderabad - 500 003. Tel: (040) 44004100 • **Thiruvananthapuram:** TC IV/962, 'Chandrika', Sree Chitra Nagar, Pipeline Road, Kawdiar, Thiruvananthapuram - 695 003. Tel: (0471) 2720025 / 65 • **Vadodara:** Ramakrishna Chambers, 7th Floor, Productivity Road, Alkapuri, Vadodara - 390 007. Tel: (0265) 2330334 / 6614100 • **Visakhapatnam:** D. No. 49-24-65/1, Near Sankarmattam Road, Madhura Nagar, Visakhapatnam - 530 016. Tel: (0891) 2748405/ 2748433 • **Vijayawada:** No. 40-1-62, Nagas Hafeez Plaza, Opposite to grand modern supermarket, Near BENZ Circle, MG. Road, Vijayawada 10. Tel No.: 0866 2484004 • **email:** [coolingsolutions@bluestarindia.com](mailto:coolingsolutions@bluestarindia.com) • **Visit us at:** [www.bluestarindia.com](http://www.bluestarindia.com) or SMS 'COOL' to 57575